

ASSEMBLY INSTRUCTIONS

Codice foglio: 997-001-00794 Rev: AA

- 1) Avvitare l'interruttore a puntale nella sede indicata in figura;

Screw-in the pressure switch into the port, as shown in the picture.

L'interruttore deve essere sempre montato per evitare fuoriuscite di olio dal cambio ed è assolutamente necessario l'impiego della rondella distanziale inclusa nel sacchetto;

The pressure switch must be always fitted in order to avoid oil leakage from the gearbox and it is strictly needed to fit the spacer washer included in the plastic bag.

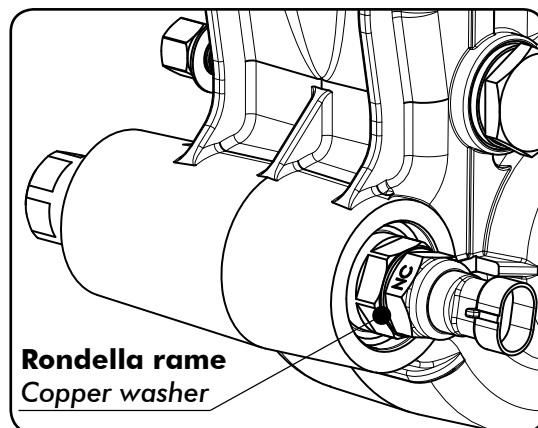
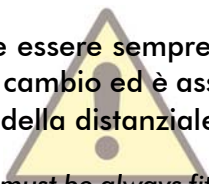

- 2) Identificare la posizione in cui verrà fissato il telecomando;

Find out the location where the cable control will be mounted.

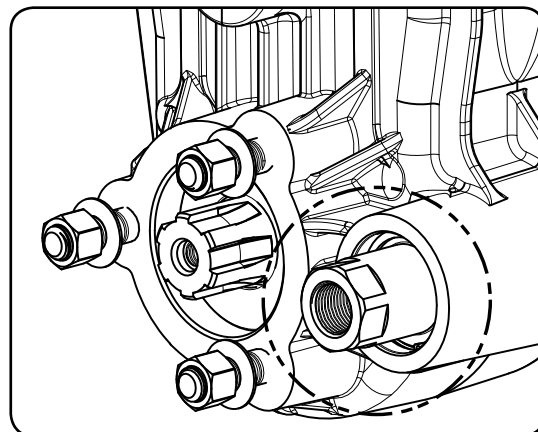

- 3) Verificare che il telecomando abbia l'estremità come rappresentata in figura;

Be sure that the cable control must have the terminal as shown in the picture.

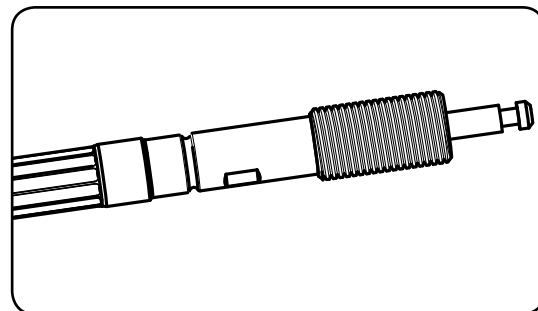

- 4) Far fuoriuscire completamente il cavo di acciaio;

Stick out the steel wire fully.

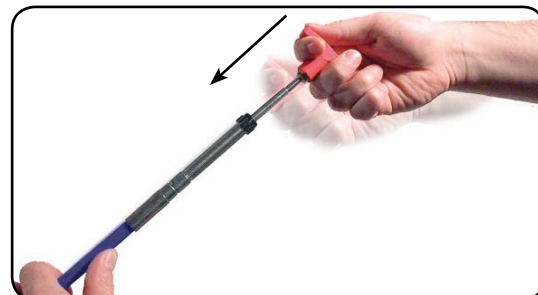
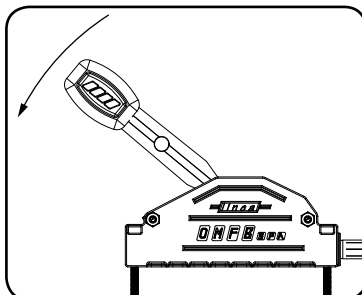

Data: Mercoledì 21 ottobre 2009

- 5) Identificare la posizione dello spacco all'interno dell'innesto;

Find out the groove inside the PTO engagement system.

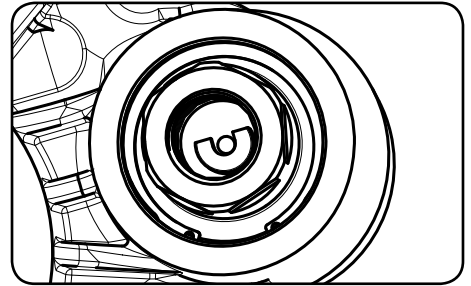

- 6) Inserire il terminale del cavo, agganciandolo come rappresentato nel disegno seguente:

Insert the terminal of the cable control and attach it as shown in the following picture.

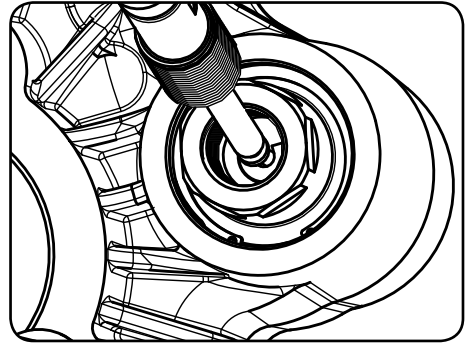

- 7) Avvitare la guaina del telecomando, serrandola fermamente, aiutandosi con due chiavi fisse.

Screw the cable tightly, helping yourself by using two spanners.

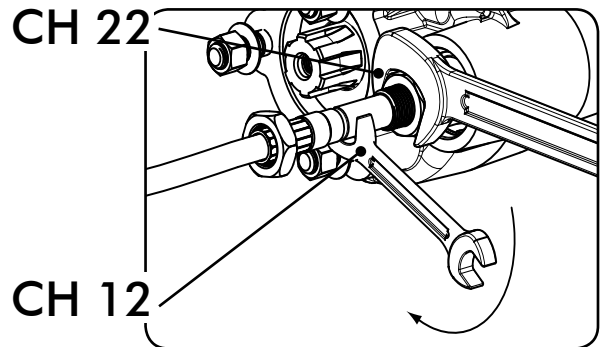
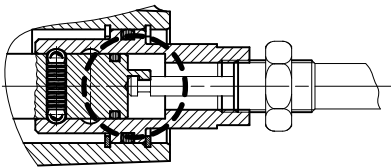

- 8) Bloccare il controdado sull'innesto utilizzando due chiavi fisse

Tight the counter-nut by using two spanners.

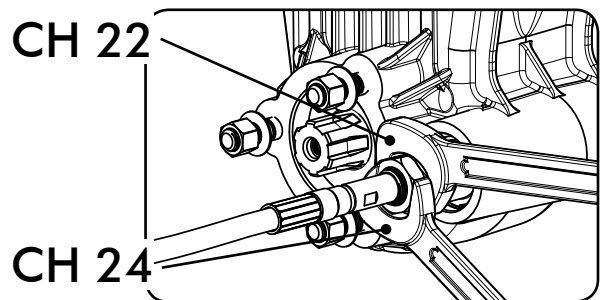
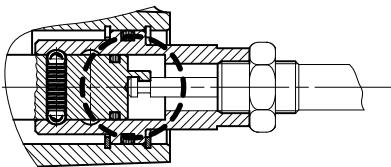

- 9) Verificare il corretto funzionamento della presa di forza, considerando che la corsa di innesto è pari a 10,5 mm.

Check the right working of the PTO taking into consideration that the engagement travel is 10,5mm.

